

REV	ECO No	DESCRIPTION	DRAWN	APPROVED	DATE
-	-	-	-	-	-
-	-	-	-	-	-

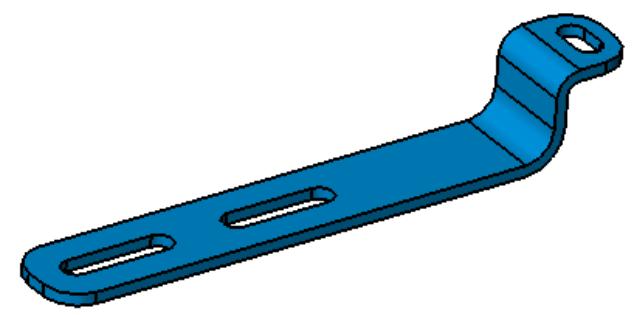
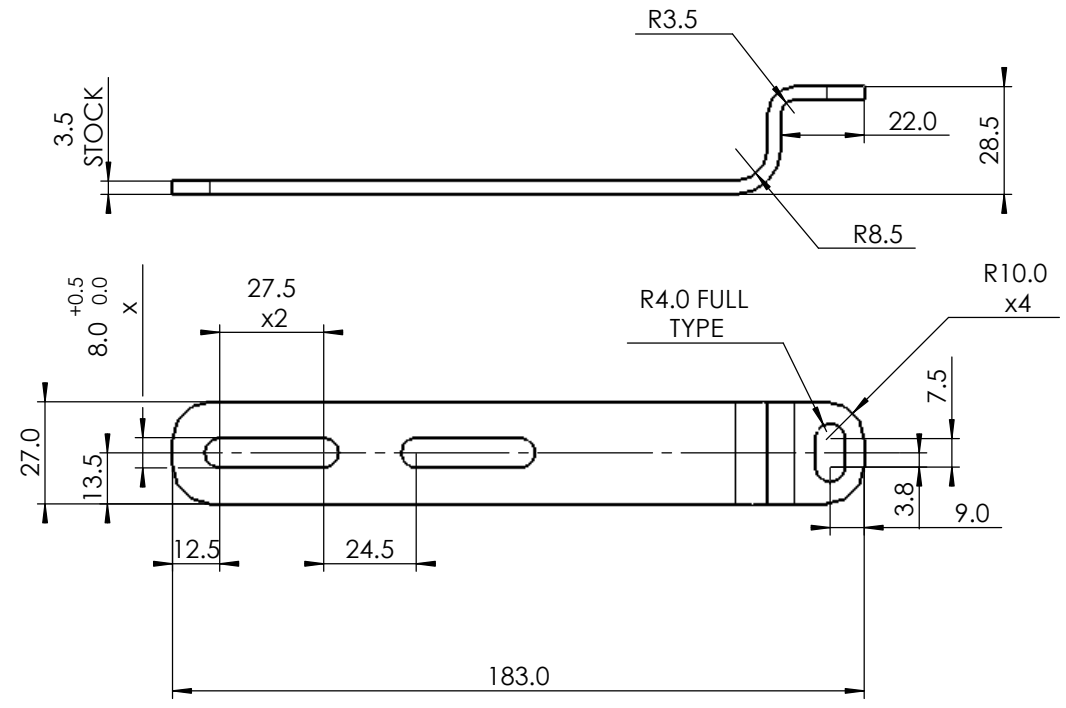

3	-	-
2	-	-
1	-	-

PACKAGING AND PACKING MATERIALS TO BE MET WITH AMAT PACKAGING SPECIFICATION P/N 0250-00098 UNLESS OTHERWISE SPECIFIED IN THE DRAWING.

MATERIAL: ST. ST. 304	UNLESS OTHERWISE SPECIFIED: MACHINING REQUIREMENTS BREAK SHARP CORNERS AND EDGES 0.2 MAX FILLET RADIUS 0.4 MAX C SINK INT. THREADS 90° TO MAJOR DIA CHAMFER EXT. THREADS 45° TO MAJOR DIA	
FINISH: 1		
SURFACE ROUGH. N7 / (N7) / (N7)	GENERAL TOLERANCES: 0 - 30 ±0.2 ANGLES ±0.5° 30 - 500 ±0.3 HOLES 0 - 10 +0.2 / -0.05 500 - 1000 ±0.5 HOLES 10+ GEN. TOL 1000 + ±1 BETWEEN HOLES ±0.05	

NAME	DATE	UNLESS OTHERWISE SPECIFIED: ALL DIMENSIONS IN MM & INCLUDE CHEM. APPLIED/PLATED FINISH. DO NOT SCALE DRAWING.	TITLE. Tool Box Bracket.
DESIGNED	--/--/----		
DRAWN	--/--/----		
CHECKED	--/--/----	PROJECT	DWG No.
APPROVED	--/--/----	NEXT ASSY	REV 0
		00XX-A0XXX-0XPX	SCALE 1:2 SHEET 1 OF 1 SIZE A3